

# The complete borosilicate safety sight and level gauge glass program

MAXOS® safety sight and level gauge glasses have proved themselves universally where visual process control is essential. This includes pressure vessels subjected to thermal and chemical stresses and liquid level gauge application.

A high safety level is secured through the use of special borosilicate glass of high chemical durability, exceptional purity and homogeneity. The low thermal expansion of our SUPRAX 8488 borosilicate glass, combined with thermal prestressing (tempering) creates a high resistance to sudden temperature changes.

The material properties values and small dimensional tolerances are guaranteed by production and quality controls. With these exceptional safety characteristics, MAXOS® safety sight and level gauge glasses can be used under extreme operational conditions. It is therefore mainly these safety aspects which influence responsible technicians again and again to choose MAXOS®.



Grinding and polishing



## MAXOS®-Product Range

Special tempered reflex and transparent level gauge glasses and disc sight glasses can be supplied in accordance to:

- DIN 7080/7081
- BS 3463
- JIS B 8211
- MIL - G - 16356 D
- Schott Auer - USA-Specification

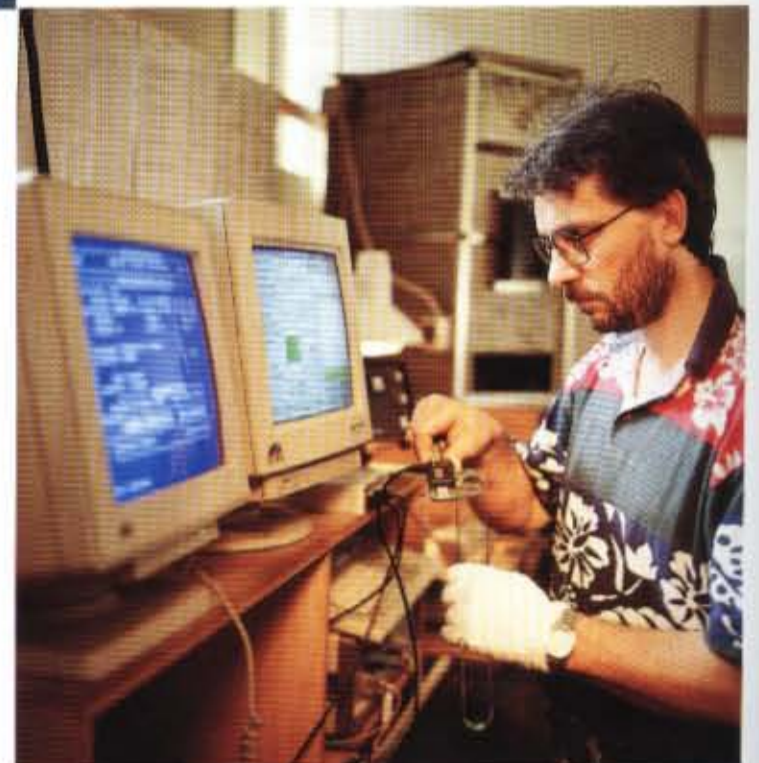

CAQ network system (computer aided quality)

# Long form level gauge glasses, reflex and transparent

## Technical characteristics

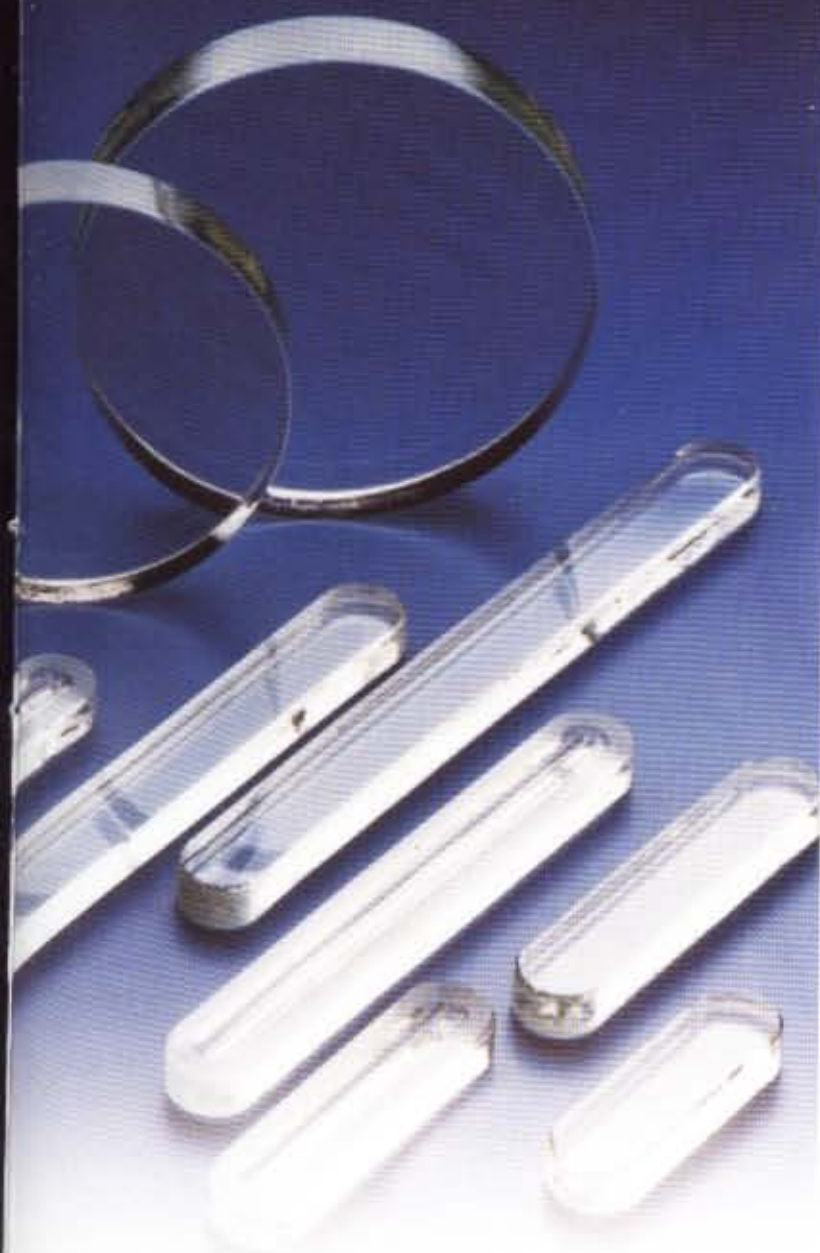

### Bending strength (typical values)

Standard level gauge glasses	
$\geq 150 \text{ N/mm}^2$	21.000 psi
Average	
$170 \text{ N/mm}^2$	25.000 psi

High pressure level gauge glasses	
$\geq 180 \text{ N/mm}^2$	26.000 psi
Average	
$200 \text{ N/mm}^2$	29.000 psi

### Surface compressive stress

Standard level gauge glasses	
$\geq 90 \text{ N/mm}^2$	13.000 psi
Average	
$100 \text{ N/mm}^2$	14.500 psi

High pressure level gauge glasses	
$\geq 100 \text{ N/mm}^2$	14.500 psi
Average	
$110 \text{ N/mm}^2$	16.000 psi

### Parallelism

Standard level gauge glasses	
$\leq 0,08 \text{ mm}$	0.003 inches

High pressure level gauge glasses	
$\leq 0,05 \text{ mm}$	0.002 inches



All leading OEM's are using MAXOS®.

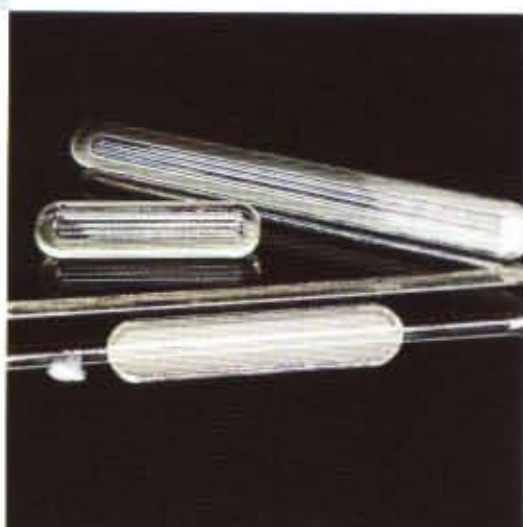

Long form level gauge glasses, reflex and transparent.

MAXOS® – a registered trademark of SCHOTT GLAS GmbH, Mainz

# Long form level gauge glasses, reflex and transparent

## Technical characteristics

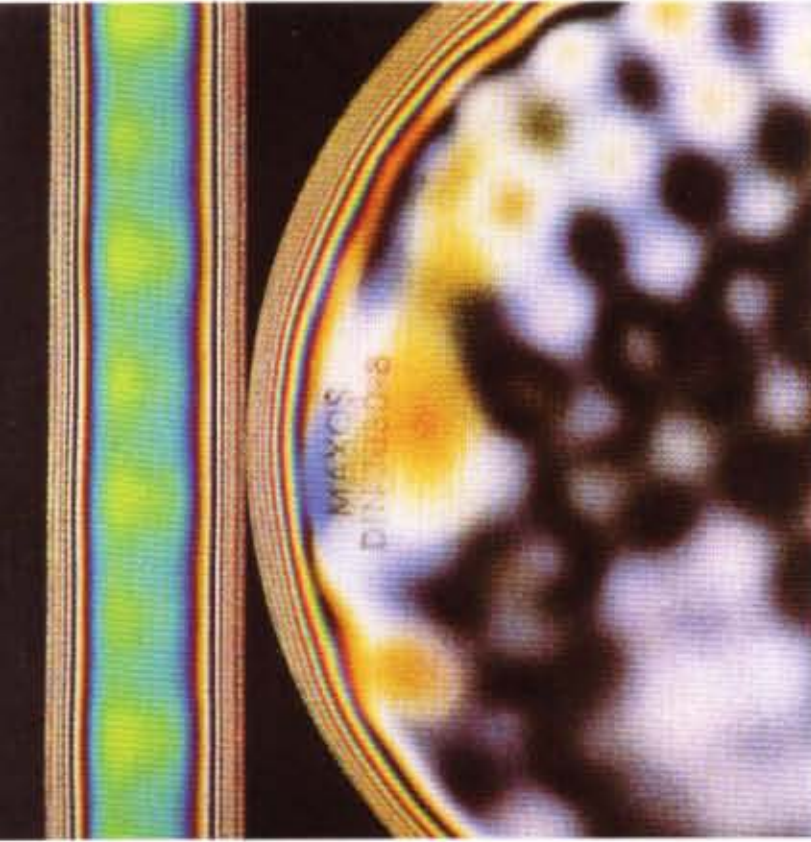

Special tempered MAXOS® glasses under polarised light.

Bending strength is determined by the surface compressive stress and the inherent resistance of the glass. The inherent resistance is heavily dependent upon the surface quality.

For safety reasons, the stress to the glasses caused by internal forces, thermal stress and vessel pressure have to be totally absorbed by the surface compressive stress so that a tensile stress of the glass surface is prevented.

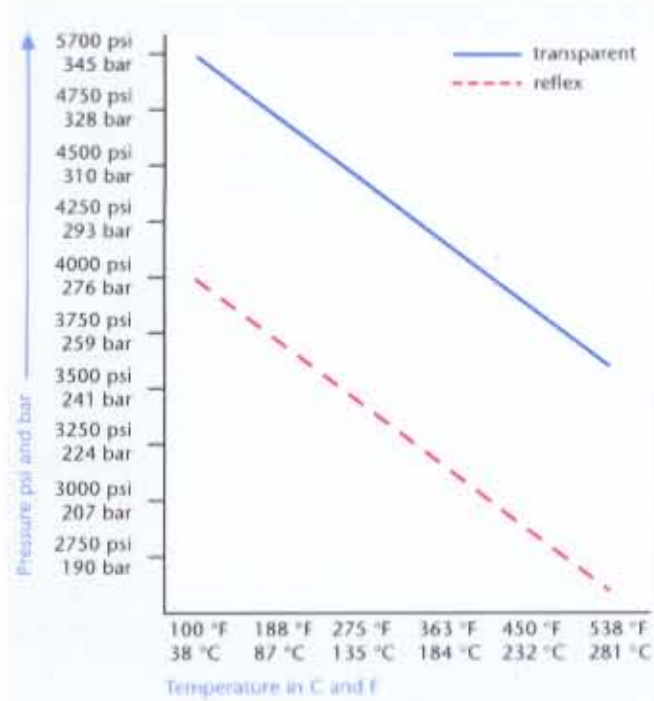

Pressure temperature graph for MAXOS®-glasses. Range of application with no technically significant glass attack.

### Application conditions

Application conditions	Maximum permissible pressure		Maximum permissible temperature	
	bar	psi	°C	°F
Saturated steam or hot water in direct contact with reflex or transparent sight glasses	35	500	243	470
Saturated steam or hot water in contact with transparent sight glasses protected with mica	103	1.500	320	608
Non-corrosive, non-steam service and no technically significant glass attack, with reflex or transparent glasses	280	4.000	38	100
Transparent sight glasses in contact with medias with no technically significant glass attack	345	5.000	38	100
High pressure transparent sight glasses in special armatures (gauges)	414	6.000	38	100

## Available sizes

Special design for REFLEX and TRANSPARENT on request:  
e.g. 21 mm thickness.

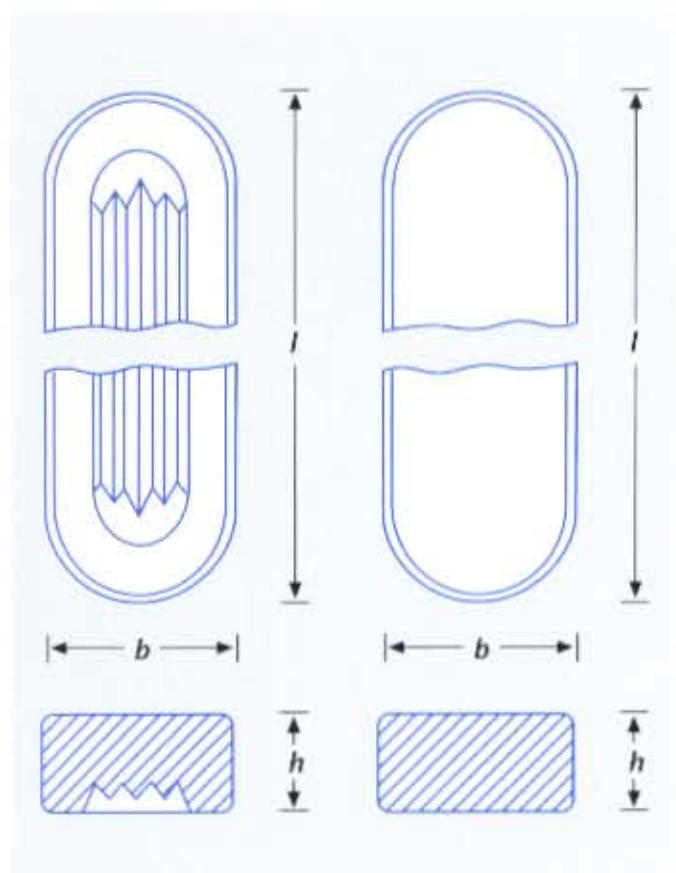

Reflex type glass  
(R form)

Transparent type glass  
(T form)

### Flatness (max.)

Size 1-3	≤ 0,05 mm	≤ 0.002 inches
Size 4-5	≤ 0,08 mm	≤ 0.003 inches
Size 6-9	≤ 0,13 mm	≤ 0.005 inches
High pressure	≤ 0,05 mm	≤ 0.002 inches

(only transparent).

### Temperature

Thermal shock resistance $\Delta T$	265 K
max. permissible temperature	300 °C 572 °F
Protected with mica	320 °C 608 °F

Size	Dimensions						max. flatness tolerance					
	Length		Width		Thickness		Standard		High pressure			
	mm	inch*)	mm	inch*)	mm	inch*)	mm	inch*)	mm	inch*)		
0	95	3.740	34	1.339	17,5	0.689	0,05	0.002	-	-		
1	115	4.500	34	1.339	17,5	0.689	0,05	0.002	0,05	0.002		
2	140	5.500	34	1.339	17,5	0.689	0,05	0.002	0,05	0.002		
3	165	6.500	34	1.339	17,5	0.689	0,05	0.002	0,05	0.002		
4	190	7.500	34	1.339	17,5	0.689	0,08	0.003	0,05	0.002		
5	220	8.625	34	1.339	17,5	0.689	0,08	0.003	0,05	0.002		
6	250	9.874	34	1.339	17,5	0.689	0,13	0.005	0,05	0.002		
7	280	11.000	34	1.339	17,5	0.689	0,13	0.005	0,05	0.002		
8	320	12.625	34	1.339	17,5	0.689	0,13	0.005	0,05	0.002		
9	340	13.374	34	1.339	17,5	0.689	0,13	0.005	0,05	0.002		
10	370	-	34	-	17,5	-	0,13	-	-	-		
11	400	-	34	-	17,5	-	0,13	-	-	-		
Tolerances*)	+ 0	+ 0	+ 0,2	+ 0.008	+ 0	+ 0	- 1,5	- 0.039	- 0,8	- 0.039	- 1,0	- 0.028

High Pressure ist nur für Transparent-Schaugläser gültig.

\*) Inch dimensions are only valid for Schott Auer - USA-Specification.

Size	Dimensions			max. Ebenheitsabweichung
	Length	Width	Thickness	
	mm	mm	mm	
1	115	30	17,5	0,05
2	140	30	17,5	0,05
3	165	30	17,5	0,05
4	190	30	17,5	0,05
5	220	30	17,5	0,08
6	250	30	17,5	0,08
7	280	30	17,5	0,13
8	320	30	17,5	0,13
9	340	30	17,5	0,13
Tolerances	up to 250 ± 0,8	+ 0,5	+ 0	
	above 250 ± 1,0	- 0,8	- 1,0	

# Physical and chemical characteristics

## Glass Type SUPRAX 8488

Coefficient of expansion

$\alpha$  20 °C/300 °C

$4,3 \times 10^{-6} \text{ K}^{-1}$

Transformation temperature

540°C

Glass temperature for the

viscosities dPas (Poise)

$10^{13,0}$

553°C

$10^{7,6}$

808°C

$10^{4,0}$

1200°C

Density at 25°C

2,31g/cm<sup>3</sup>

Modulus of elasticity

$67 \times 10^3 \text{ N/mm}^2$

Poisson's ratio  $\mu$

0,20

Thermal conductivity

$\lambda$  at 90°C

1,2  $\frac{\text{W}}{\text{m}\cdot\text{K}}$

Refractive index  $n_d$

1,484

( $\lambda = 587,6 \text{ nm}$ )

Photoelastic

parameter K

$3,2 \times 10^{-6} \text{ mm}^2/\text{N}$

Chemical characteristics	Hydrolytic resistance	Acid resistance	Alkali resistance
Test acc. to	DIN ISO 719	DIN ISO 1776	DIN ISO 695
max. abrasion acc. to DIN ISO	0,1	< 100 $\mu\text{g Na}_2\text{O}$ each 100 $\text{cm}^2$	> 75 - 175 mg each 100 $\text{cm}^2$
MAXOS® max. abrasion	0,050	< 40 $\mu\text{g Na}_2\text{O}$ each 100 $\text{cm}^2$	< 100 mg each 100 $\text{cm}^2$
MAXOS®	HGB 1	-	class A2

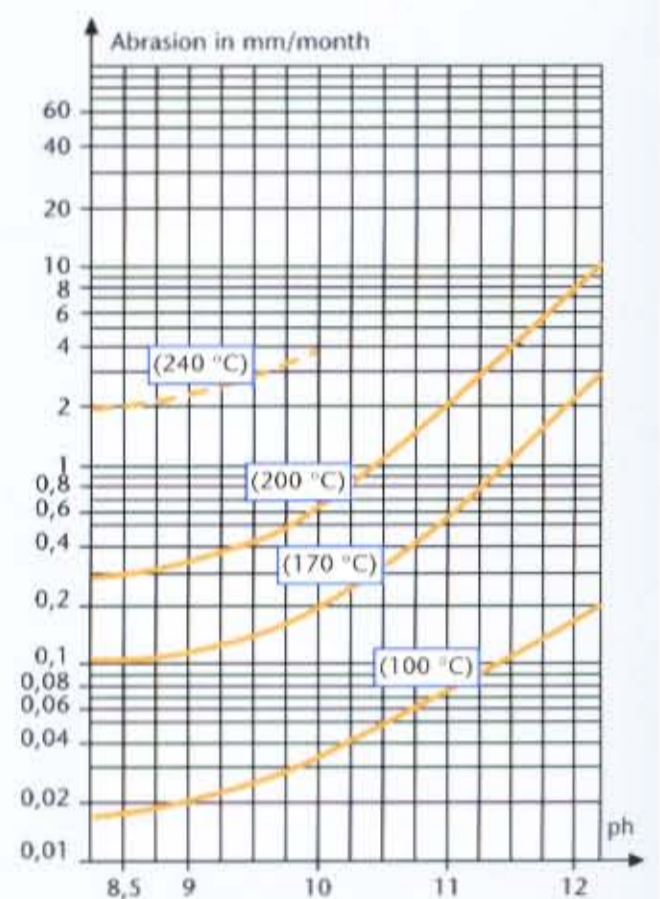

The abrasion of MAXOS®-glass in watery phase for several temperatures as a function of the pH-value.

## Disc sight glasses

### Technical characteristics

#### Dimensional tolerances (DIN 7080)

Diameter

up to 135 mm

$\pm 0,5 \text{ mm}$

150 to 200 mm

$\pm 0,8 \text{ mm}$

above 200 mm

$\pm 1,0 \text{ mm}$

Thickness

up to 20 mm

+ 0,50 mm / - 0,25 mm

above 20 mm

+ 0,80 mm / - 0,40 mm

Bending strength

$\geq 160 \text{ N/mm}^2$

23.000 psi

Surface compressive stress

$\geq 100\text{--}140 \text{ N/mm}^2$

14.500–20.000 psi

Parallelism

$\leq 0,20 \text{ mm}$

0.008 inches

Flatness

Diameter:

up to 100 mm  $\leq 0,05$

above 100 up to 150 mm  $\leq 0,08$

above 150 up to 200  $\leq 0,12$

above 200 mm  $\leq 0,15$

Thermal shock resistance  $\Delta T$

265 K

Max. permissible temperature

300 °C

572 °F

protected with mica

320 °C

608 °F

## Available size

Special dimensional design on request, e.g. Ø min. 30 – max. 265 mm and thickness min. 10 – max. 30 mm.



All MAXOS® glasses are marked with a production code number.

### Calculation of the glass thickness (acc. to DIN 7080)

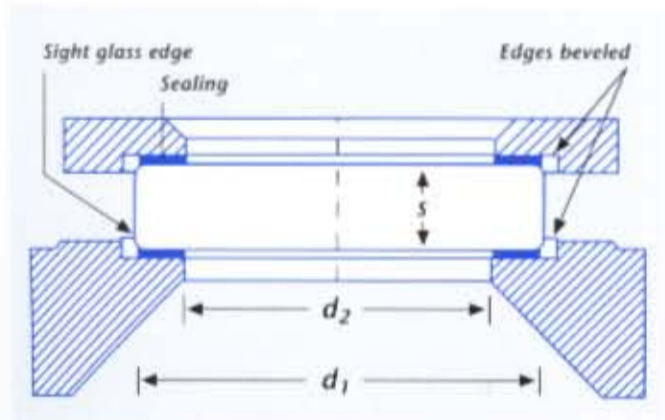

$$s \geq 0,55 \cdot d_m \sqrt{\frac{p \cdot S}{10 \cdot \sigma_{DV \text{ zul.}}}}$$

- $s$  Theoretical minimum glass thickness in mm
- $d_m$   $\frac{d_1 + d_2}{2}$  Mean sealing diameter in mm
- $d_1$  Glass and sealing outside diameter in mm
- $d_2$  Sealing inside diameter in mm
- $p$  Permissible pressure in bar
- $\sigma_{DV \text{ zul.}}$  Min. value of surface compressive stress in N/mm<sup>2</sup>
- $S$  Safety factor = 5

Dimensions $d_1 \times s$ (mm)	Inspection aperture $d_2$ (mm)	Permissible pressure in bar	Dimensions $d_1 \times s$ (inch)	Inspection aperture $d_2$ (inch)	Permissible pressure in psi
30 x 15	20	200	1.181 x 0.591	0.787	2900
31,6 x 12,75	20	150	1.244 x 0.502	0.787	2175
34 x 17	24	200	1.339 x 0.669	0.945	2900
35 x 7	25	25	1.378 x 0.276	0.984	363
40 x 10	30	40	1.575 x 0.394	1.181	580
40 x 12	30	50	1.575 x 0.472	1.181	725
45 x 10	32	40	1.772 x 0.394	1.260	580
45 x 12	32	50	1.772 x 0.472	1.260	725
50 x 10	35	25	1.969 x 0.394	1.378	363
50 x 12	35	40	1.969 x 0.472	1.378	580
55 x 10	40	25	2.165 x 0.394	1.575	363
60 x 10	45	16	2.362 x 0.394	1.772	232
60 x 12	45	25	2.362 x 0.472	1.772	363
60 x 15	45	40	2.362 x 0.591	1.772	580
60 x 20	45	95	2.362 x 0.787	1.772	1377
63 x 8	48	8	2.480 x 0.315	1.890	116
63 x 10	48	16	2.480 x 0.394	1.890	232
63 x 12	48	25	2.480 x 0.472	1.890	363
63 x 15	48	40	2.480 x 0.591	1.890	580
65 x 10	50	12	2.559 x 0.394	1.969	174
65 x 15	50	40	2.559 x 0.591	1.969	580
70 x 12	55	16	2.756 x 0.472	2.165	232
70 x 15	55	25	2.756 x 0.591	2.165	363
75 x 12	60	16	2.953 x 0.472	2.362	232
80 x 10	65	10	3.150 x 0.394	2.559	145
80 x 12	65	16	3.150 x 0.472	2.559	232
80 x 15	65	25	3.150 x 0.591	2.559	363
80 x 20	65	40	3.150 x 0.787	2.559	580
90 x 10	70	8	3.543 x 0.394	2.756	116
92 x 10	72	8	3.622 x 0.394	2.835	116
95 x 10	75	6	3.740 x 0.394	2.953	87
95 x 15	75	16	3.740 x 0.591	2.953	232
100 x 10	80	7	3.937 x 0.394	3.150	101
100 x 12	80	10	3.937 x 0.472	3.150	145
100 x 15	80	16	3.937 x 0.591	3.150	232
100 x 20	80	25	3.937 x 0.787	3.150	363
100 x 25	80	40	3.937 x 0.984	3.150	580
113 x 15	88	10	4.449 x 0.591	3.465	145
115 x 15	90	10	4.528 x 0.591	3.543	145
120 x 15	95	10	4.724 x 0.591	3.740	145
125 x 15	100	10	4.921 x 0.591	3.937	145
125 x 20	100	16	4.921 x 0.787	3.937	232
125 x 25	100	25	4.921 x 0.984	3.937	363
125 x 30	100	40	4.921 x 1.181	3.937	580
130 x 15	105	10	5.118 x 0.591	4.134	145
135 x 25	110	25	5.315 x 0.984	4.331	363
150 x 10	125	2	5.906 x 0.394	4.921	29
150 x 15	125	8	5.906 x 0.591	4.921	116
150 x 20	125	10	5.906 x 0.787	4.921	145
150 x 25	125	16	5.906 x 0.984	4.921	232
150 x 30	125	25	5.906 x 1.181	4.921	363
175 x 20	150	10	6.890 x 0.787	5.906	145
175 x 25	150	16	6.890 x 0.984	5.906	232
175 x 30	150	25	6.890 x 1.181	5.906	363
200 x 20	175	8	7.874 x 0.787	6.890	116
200 x 25	175	10	7.874 x 0.984	6.890	145
200 x 30	175	16	7.874 x 1.181	6.890	232
250 x 20	225	4	9.843 x 0.787	8.858	58
250 x 25	225	8	9.843 x 0.984	8.858	116
250 x 30	225	10	9.843 x 1.181	8.858	145
265 x 30	240	8	10.433 x 1.181	9.449	116